



Cascade Caver

Newsletter of the Cascade Grotto of the National Speleological Society

Volume 32, No. 1

January 1993

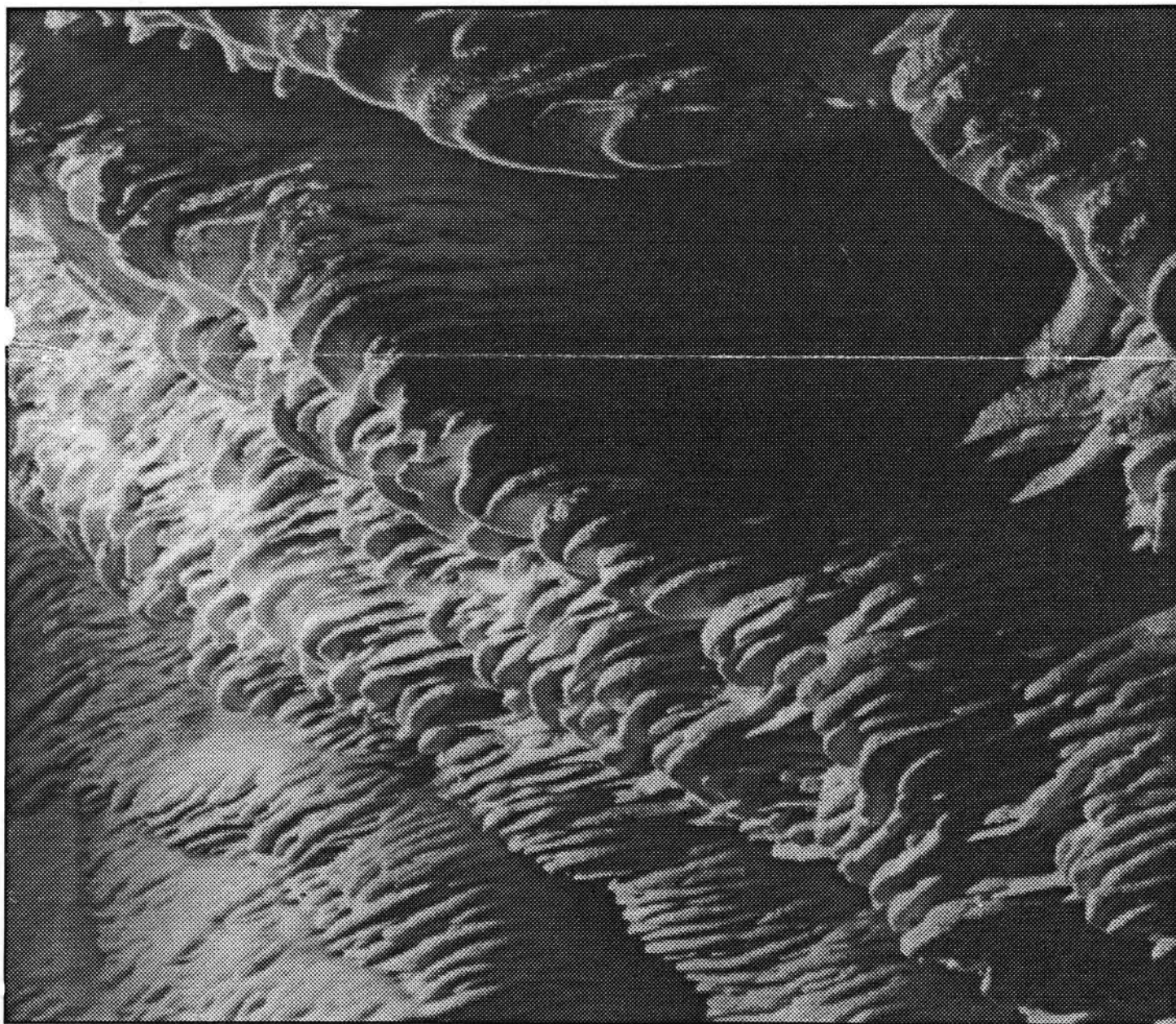

Cascade Grotto

Regular grotto Meetings are held monthly at 7:00 PM on the third Friday of each month at the University of Washington room 6 in the basement of Johnson Hall. Business meetings are held on odd numbered months immediately following the regular grotto meetings.

- GROTTO CHAIR** Karl Steinke 000-0000 (home)
(work)
- VICE CHAIR** Paul Ostby 823-5107 (home)
- SEC/TREAS** Greg Hollenbeck 668-7578 (home)
782-3831 (work)
- Co-EDITOR** Bill Bennett 255-1466 (home)
- Co-EDITOR** Christine Schlemmer 255-1466 (home)
- ASSISTANT LARRY MCTIGUE** 850-8614 (home)
EDITOR
- REGIONAL/REP** Ben Tompkins 546-8025 (home)
- LIBRARIAN** (vacant position)
Anyone want to give the library a good home?
- CAVE & TOPO MAPS** Rod Crawford 543-9853 (work)
eves. (U.of W./Burke Museum)
- CAVE REGISTERS** Mike Wagner 282-0985 (home)
- GROTTO REP 1993 NSS CONVENTION**
Mike Compton 535-5144 (home)
- Grotto address**
P.O. BOX 75663
Seattle, WA 98125-0663
- Editor's address**
Bill Bennett
1626 Grant Ave. S. #C202
Renton, WA 98055
- NSS NORTHWEST REGIONAL CAVING ASSOCIATION**
CHAIR Dave Klinger (509)548-5480
Leavenworth, WA
- VICE/CHAIR** Ben Tompkins (206)546-8025
Seattle, WA
- TREAS** Phil Whitfield (604)372-5079
B.C., Canada
- SEC** John Baz-Dresch. (509)663-7173 or 663-1428
Wenatchee, WA
- NSS NATIONAL CAVE RESCUE COMMISSION (NCRC)**
NORTHWEST REGIONAL COORDINATOR
Rick Rigg (208)524-5688 (home) (208)526-6816 (work)
Idaho Falls, ID
- NSS DIRECTORS** (Cascade Grotto)
1991-1994 Bill Halliday (615)352-9204
Nashville, TN
- 1990-1993** Tom Strong 938-3957(home) 822-8880(work)
Seattle, WA
- NSS BULLETIN ADVISORY BOARD**
CHAIR Tom Strong 938-3957(home) 822-8880(work)
Seattle, WA
- NSS CAVE CONSERVATION & MANAGEMENT**
SECTION
CHAIR Rob Stitt (206)283-2283
Seattle, WA
- NSS GRAPHIC ARTS SALON COMMITTEE**
CHAIR John Baz-Dresch (509)663-7173 or 663-1428
Wenatchee, WA

Copyright 1992 by Cascade Grotto. All rights reserved.

The *Cascade Caver* is published by the Cascade Grotto a Local Chapter of the National Speleological Society. Any material that is not copyrighted by an individual or another group may be copied or reprinted by internal organizations of the National Speleological Society provided that credit is given to the author and to the *Cascade Caver* and a copy of the publication containing the material is sent to the Editor. Other organizations must contact the Editor. Unsigned articles may be attributed to one of the editors.

Dues which include a subscription to the *Cascade Caver* are \$10.00 per year. Additional members in the same house hold are \$2.00. Subscriptions only are also \$10.00.

All materials to be published and exchange publications should be sent to the Editor.

Subscription requests and renewals should be sent to the grotto Treasurer.

In This Issue

Up-coming events	1
Grotto News	1
Oregon Caves Restoration Project	4
Show Caves of South Bass Island Ohio	7
Hell Roaring Ridge Cave Survey	7
Mount St. Hellens Trip	8
Grotto Library Abstracts	9

On the Cover: "Folia Formation" Indian Burial Cave Garrison, Utah. Photo by Michael Compton.

Up Comming Events

- Cascade Grotto Meeting January 15th
- Cascade Grotto Meeting February 19th
- Cascade Grotto Meeting March 19th
- NSS Convention Pendelton, OR August 2-6, 1993

If you wish to list any up comming events please send them the editors.

Bat Droppings

Bat Droppings is a column of bits and pieces of useful caving information from a variety of sources and any suggestions for future droppings is appreciated.

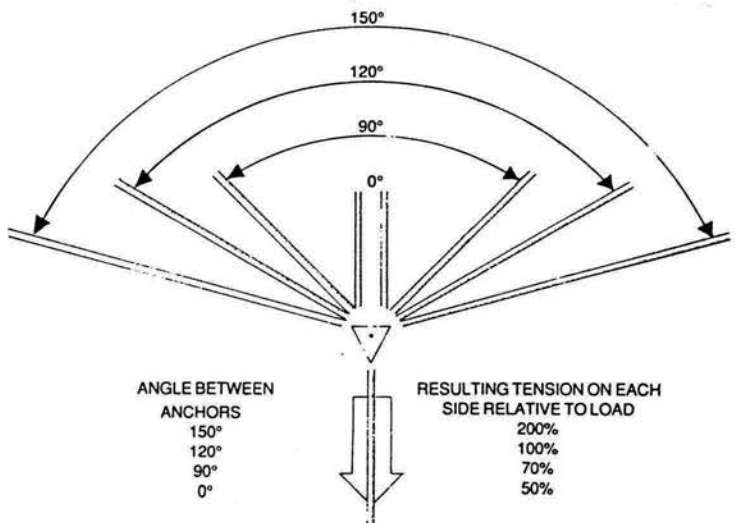
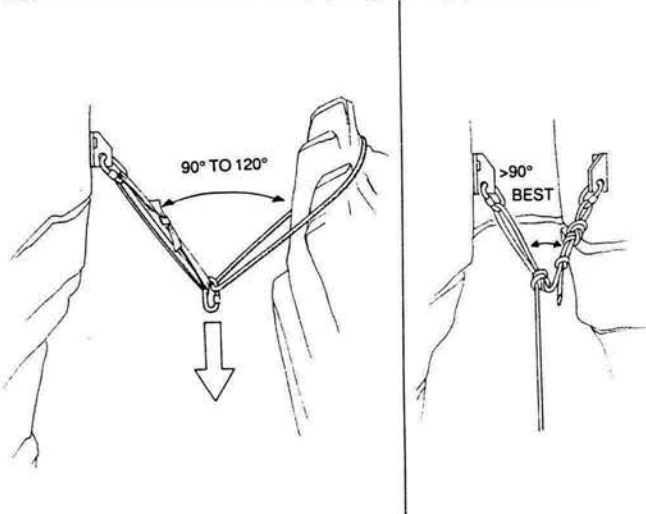

Remember that as the angle between your anchors increases the load on each anchor increases. It is recommended that you should never exceed 120 degrees between anchors and an angle of 90 degrees or less is generally a safe working angle.

Grotto News

Welcome to the 1993 *Cascade Caver*, as you can see the caver has a new look and if you look in the fine print on page 2 a new editorial staff. The Grotto would like to thank Larry McTigue for his contribution to the *Caver* and he has vowed to publish those back issues someday.

The new co-editors Bill Bennett and Christine Schlemmer are fairly recent additions to Cascade Grotto (June or was it July?). They are originally from California and have done most of their caving in the Central and Southern Sierra. They could use as much help and materials as possible in their attempt to publish the *Caver*.

The Christmas party was a great success and the Grotto would like to thank Wendel Pound for the use of his house. This years Squeeze Box Competition was a tie between Lorry Safford and Laura Lasater. They wormed their way to places mere mortals feared to tread.

Election results for Grotto officers for '93 are in and are as follows:

- Grotto Chair: Karl Steinke
- Vice Chair: Paul Ostby
- Sec/Treasurer: Greg Hollenbeck

Thank you to last years Grotto Chair Steve Sprague for a job well done. Also thanks to Greg Hollenbeck for going on to a second term as Secretary/Treasurer.

Oregon Caves Restoration Project

By Michael Compton



Photo By Mike Compton

Oregon Caves Restoration Crew, Cascade Grotto, November 7, 1992.

Top Row: Ranger Dave Miller, Christine Schlemer, Jim Harp, Robert Mitchell, Scott Davis.

Bottom Row: Mark Secilia, Paul Ostby, Bill Bennett, Katrina Peter, Michael Compton.

On November 6th and 7th 1992 the Puget Sound Grotto and the Cascade Grotto joined forces the work on the Oregon Caves Restoration Project.

We arrived at Oregon Caves National Monument the evening of Nov. 6th and were met by Oregon Caves Company general manager Chuck Davis and guide Dave Stepp.

The restoration crew consisted of Jim Harp, Paul Ostby, Katrina Peter, Robert Mitchell, Bill Bennett, Christine Schlemer, Scott Davis and myself, Michael Compton.

Chuck Davis had arranged for us to sleep above the gift shop in the guides quarters, and had thoughtfully provided electric heaters in the room for our comfort on those cold November nights.

Those of us that had arrived that afternoon were treated to an excellent dinner in the staff dining room. After dinner we retired to the main room of the Chateau to lounge on front of the fireplace and sip eggnog provided by our host.

The Chateau itself is worth the trip to the caves. It was completed in 1934 and is listed on the national register of historic places. It is a beautiful six story hotel that blends in

nically with the environment through the clever use of local materials.

Breakfast was served at 7:30 the following morning and was the usual outstanding feast. At 9:00 we assembled in front of the cave to meet our supervisor on this portion of the project, Ranger Dave Miller. Our assignment was to remove dirt fill that had been dumped in the caves when the trails were built.

In the 1920's and 1930's as the commercial trails were constructed, rubble from the tunnels that were blasted was dumped into any convenient hole. As we now know, this had a dramatic effect on the airflow through the cave, drying out many of the living parts of the cave and slowing its growth. The purpose of this restoration project is to remove the rubble and restore the airflow to its natural condition.

The mechanics of rubble removal consist of filling 5 gallon buckets with dirt and rocks then carrying the buckets outside and dumping them into a truck to be hauled away. We quickly realized that about half full buckets were heavy enough to be carrying through a cave. Fortunately we were fairly close to

the entrance and only had to haul them a fraction of the distance of some of the restoration groups.

At noon we ate lunch and then continued our work into early afternoon. We removed enough dirt and rock to more than half fill the dump truck.

After several hours Dave Miller decided we had done enough for the day and took us on a trip along the tour route. We then returned to our quarters to clean up for dinner.

The dinner Saturday evening was considered by some of us to be the best part of the trip. It was nothing less than a full turkey dinner with all the trimmings. Just the kind of dinner you would want to eat before a wild cave tour.

After dinner we assembled in front of the cave entrance to meet with our guide, Dave Stepp for the promised wild cave tour. As usual Dave exceeded our expectations by leading us thorough crawls, climbs and remote passage off of the tour route. Not only was Dave a great guide but he was an excellent cook as well!

During our wild tour the cave lighting was shut off which provided for a totally different experience. It was like being in a different cave altogether. Several hours later we emerged tired but certainly satisfied. The hot showers at the bunkhouse were quite welcome after a hard days caving.

After breakfast the next morning we said our good-byes until next time and began the long journey home.

Jim Harp and I continued our caving trip by looking for "No Name Cave" in the hills above Grants Pass. Using a photocopied map from 1966, we spent all day Sunday looking for the cave. We were given directions by a logger who sent us to a house in the woods where we were then told we were lost. We were then given directions leading us to a limestone quarry where we met another caver from Tennessee looking

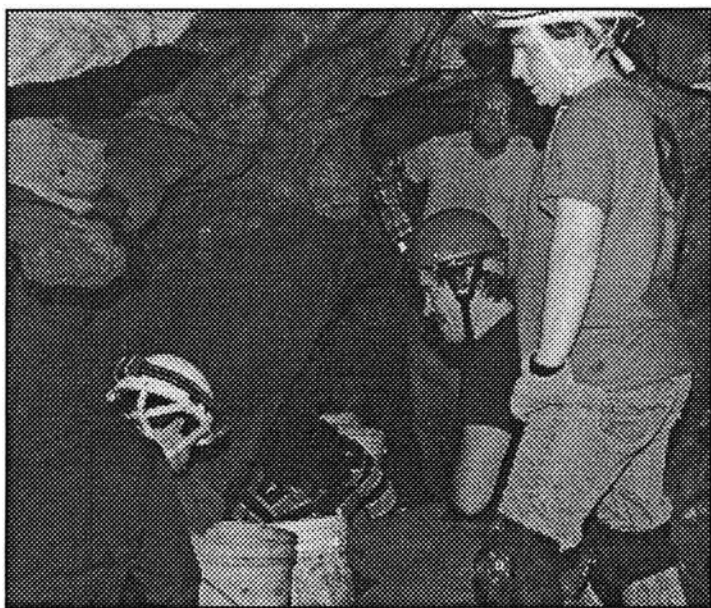

Paul Ostby needed a lot of supervision in his digging efforts

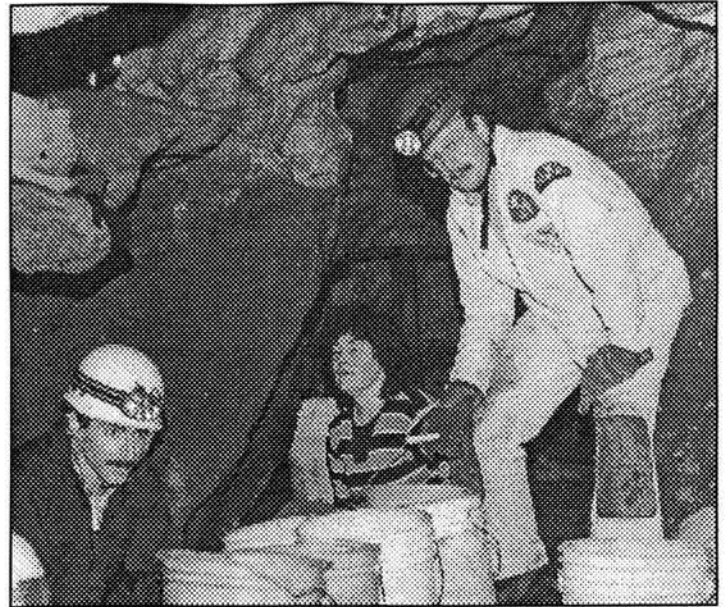

Photo By Mike Compton

for the same cave. At the quarry we did find a small cave that wet in a few feet with just enough room to turn around in.

After driving around aimlessly on logging roads for a while, we met up with the man we had talked to earlier at the house in the woods. He was in the area hunting and offered to show us to the cave. We trekked up the road in his truck until we could go no further and finished the route on foot. After a 45 minute hike to the top of the hill and then back down the other side we finally were at the cave entrance! In the meantime we came across the Tennessee caver and his dog who accompanied us to the cave.

We took a quick tour of the cave because by the time we got there it was 4:30 and we didn't want to have to find our way back to the car in the dark. The map shows 850 ft. of passage mostly consisting of two large rooms. It is well known locally and is used as the popular party spot so vandalism and trash was evident. There were some nice formations that managed to survive because they were too big to break off and steal.

By the time we made it back to the car it was getting quite late so Jim and I decided to camp at the quarry that evening and continue our caving excursion in the morning. After breakfast the next morning in Grants Pass, we headed for lava tube country in Bend, Oregon.

We arrived in La Pine that afternoon, made a groceries and gas stop and headed to the caving area. Our first stop was "Derrick" cave, arriving just before dark. We set up camp and went into "Derrick".

"Derrick" cave is a 1200 ft. lava tube, all walking passage with a couple of skylights along the way. The big room is 46 ft. high and 80 ft. wide. The cave contains some tube in tube formations, some shelves and short upper chambers. Near the entrance, under the skylights is a popular camping place with

Photo By Mike Compton

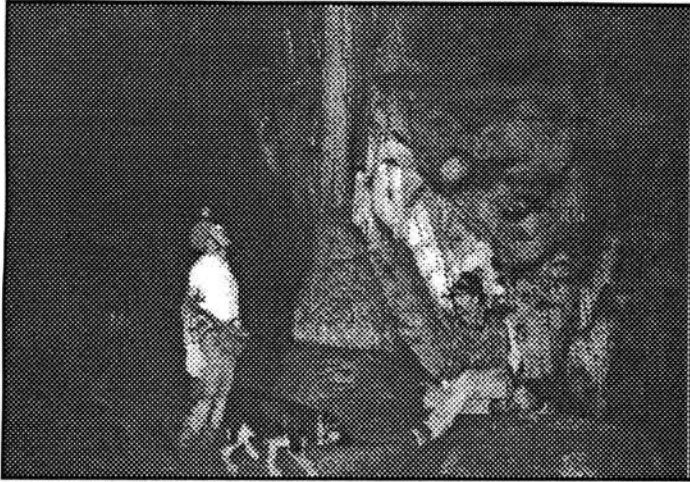

Photo By Mike Compton

Jim Harp and the Tennessee Caver in No Name Cave.

several firepits inside the cave. The upper end of the cave past the entrance sink was an area used as a civil defense cache in the early 60's. The only remnant is a steel door frame.

Jim and I camped near "Derrick" that night and nearly froze to death with temperatures well below freezing and a stiff wind blowing. The following morning we ate our breakfast of frozen doughnuts and coffee and moved on to "Charlie the Cave".

"Charlie the Cave" is a part of the Arnold Lava tube System and is a multi-level tube with about 2400 ft. of passage. The upper part of "Charlie the Cave" has a bat gate in the entrance

because it serves as a nursery colony in the summer. The gate was missing but the rest of the structure was intact.

In the sink below the bat gate is the entrance to the main part of the cave. This is an interesting and fun cave but unfortunately it is well known and used as a party cave as well.

I have been to this cave several times before but was never able to see the upper level as it was a skylight type entrance. This trip someone had constructed a crude ladder which allowed access to this upper portion of the cave. I climbed the ladder but Jim elected not to try. The upper passage went both ways quite a distance with some tube in tube, collapsed floor and flow marks along the way. The end of this section is a lava seal at the entrance end and a breakdown choke at the other.

After climbing down to where Jim waited, we started back out picking up beer bottles and cans along the way. It was now mid afternoon and we had to start the trip back home.

We hope to make the Oregon Caves Restoration Project an annual event, scheduled for the first weekend in November, as a joint effort between the Cascade and Puget Sound Grottos. The trips are limited to 21 people so plan in advance for next years trip because the spots will fill up quickly.

I would like to thank the following people for making this trip possible: John Roth of the Oregon Caves National Monument, in charge of the restoration work; Dave Miller, ranger; Chuck Davis, General Manager of the concession for the Oregon Caves Co. and Dave Stepp, Oregon Caves Guide.

A special thanks to the Oregon Caves Co. for providing food and logging at their expense, and showing a great cave conservation ethic.

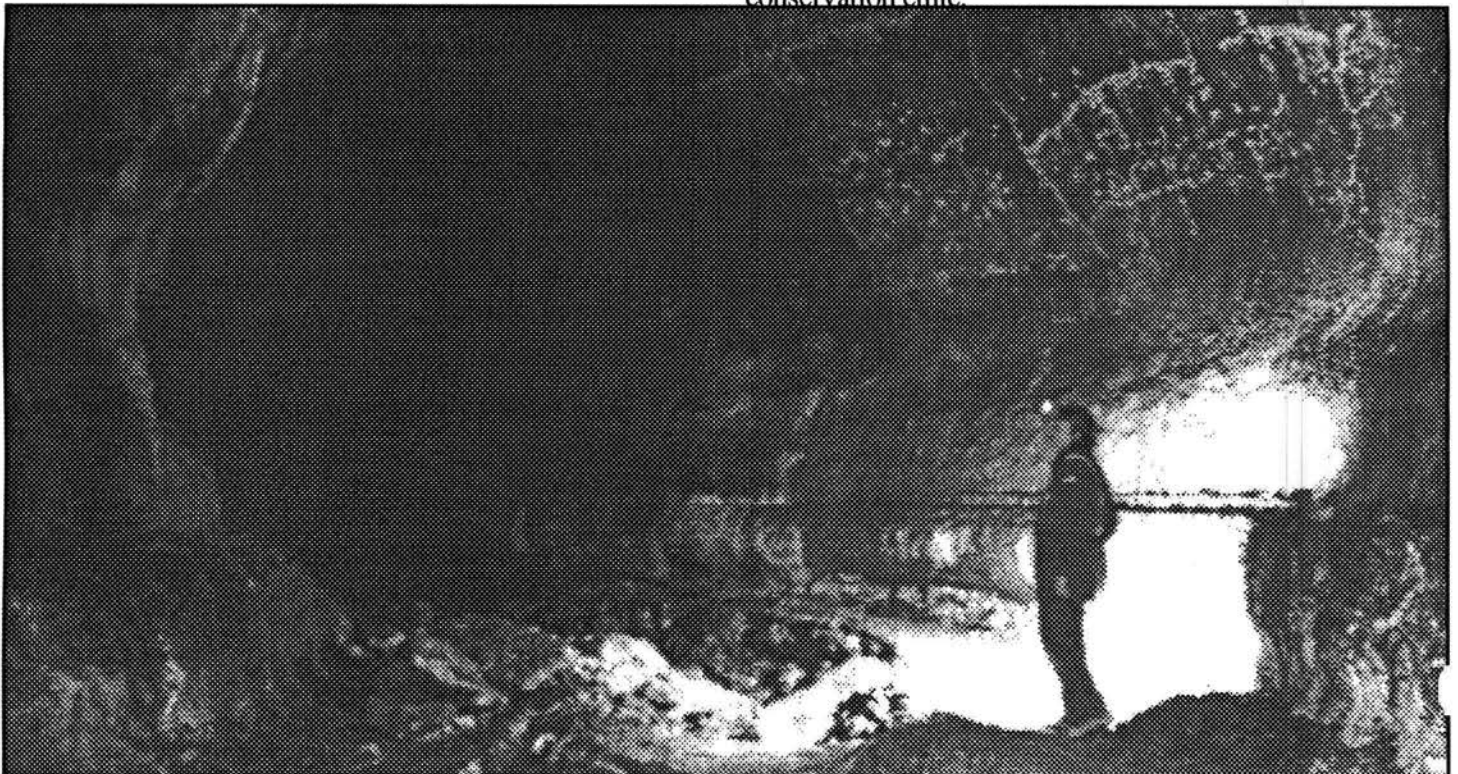

Mike Compton in Derrick Cave near Bend Oregon.

Photo By Mike Compton

Show Caves of South Bass Island, Ohio

By William R. Halliday, M.D.

On Sunday August 9, 1992, Ross and I had a look at the show caves of South Bass Island in the West end of Lake Erie: Crystal Cave and Perry's Cave. The former can be summed up in one sentence. "It's even smaller than I expected but the crystals are enormous, well worth the admission price of \$3.00. The admission fee also includes admission to the winery overhead and a glass of wine (while the wine has the foxy flavor of Catawba grapes, it was quite refreshing when ice-cold). The crystals are of celestite and are textbook examples. One is almost two feet long where it extends from the cave wall. It is regrettable that the cave is only about 20 feet long and 10 feet wide. A guide sits at the bottom of the entrance steps and gives a bit of patter before herding visitors back to the surface.

Perry's Cave is just across the road but seems speleogenetically unrelated to Crystal Cave. It is about 200 feet long and 30 to 50 feet wide. Mostly it is 4 to 7 feet high. Few speleothems are present. It descends to and below the level of Lake Erie and some cave divers (from the National Speleological Society), according to the guide, are planning to return for further underwater exploration this Fall. This cave, long has been said to have been formed by hydration of a bed of anhydrite but the current cave diving may alter this theory. Its management is a member of the National Caves Association and materials of the American Cave Conservation Association are evident. They seem to be doing a good job with a little cave in an excellent location—the island teems with tourists in the summer.

We didn't have time to check out Hole in the Ground Restaurant. If anyone knows whether it's in a cave or sink-hole, please let me know.

Speleocollectors may be interested in the wine labels on the "champagne" sold at the winery at Crystal Cave. They read:

HEINMAN'S
Crystal Cave
Fine American
CHAMPAGNE
Premium Sparkling Wine-Charvat Bulk Process
Selected by Heineman Winery-Put In Bay
Produced and Bottled by Miami Valley Winery,
Silverton, Ohio

Hellroaring Ridge Cave Survey

By Howard W. Hoyt

In August, my father and I went back to a cave near the Mazama Glacier on Mt. Adams. I had spotted it two or three years earlier and wanted to document it. The cave is about 2 miles from the Bird Creek Meadows parking lot and has a very visible entrance just below the top of a small cliff. At the base of the cliff is a permanent snow patch and shortly after the cliff is the glacier. I am not knowledgeable enough about geology to know what type of rock the cliff is made of or why the cave is in that particular spot.

The cave consists of two main sections: a sharp entrance decline floored with breakdown and dirt, and a flat floored chamber. There are no side passages or rooms. From the entrance to the main room is 50 feet and from the room to the terminus is another 50 feet. Aside from the 7 foot entrance the rest of the ceiling height is quite consistent at 12 to 15 feet. The widest section of the cave is 23 feet. Because of the large entrance, light reaches the end but it does become difficult to see the floor.

The most interesting feature of the cave, aside from its high location, is the small amount of flowstone near the entrance. Tiny 1/2 inch stalagmites can also be noted. Charcoal near the entrance shows evidence of it being used for a shelter, and it appears that the cave remains fairly dry. Many footprints attest to fairly frequent visitation.

In Caves of Washington, a "legendary" cave on Hellroaring ridge is mentioned and is called "Deadman's Cave". However, the original article describing Deadman's Cave (wherein an old miner was found dead) was said to be at the base of the mountain, and actually sounds more like dynamited cave. It seems that Halliday confused two rumors, and that the cave we visited is the Hellroaring Ridge rumor cave, not Deadman's Cave. So the question remains, what is the name of the cave we went to.

A topo map of the area and survey drawing are on the following page.

Mount St. Helens trip on 11/28/92

by Steve Sprague

I received a note from Gloria (a member of Sligo Grotto, Maryland) that if there was a trip planned around thanksgiving she would like to come along. This sounded like a good excuse for a trip so I wrote back that she should plan on one. After a couple of phone calls November 28th was settled on.

I picked up people at the movie theaters at Northgate and Southcenter and we were on our way, arriving at Jack's Restaurant near Jim and Libbey Nieland's home about 9:30. Jim had organized a group from Oregon and Willamette Valley Grottos to set monuments at the cave entrances in the area, and we were all meeting for breakfast. Jim Harp, and Jerry Thompson had come down the night before and stayed at Jim and Libby's house. Proof that the world is small was afforded when Gloria saw Roger Cole (an old Cascade Grotto member who now lives in Vancouver) seated at the table. Roger and Gloria were caving buddies from when Roger lived in Maryland!

We got a bite to eat and retired to Little Red River Cave. This was the first lava tube that Gloria had been in and we enjoyed pretending that we knew something about the speliogenesis of lava caves. I don't think she realized that we were just making it up as we went along! We toured the cave to near the end and met some of the breakfast club on returning to the exit. Then it was our turn to make like a baby and head out.

We toured the board walk of the Trail of Two Forests (Lava Cast Picnic Area), and then headed for Lake Cave. Gloria had mostly borrowed equipment so had not been ready for the cold humidity of the caves and wisely decided not to go to this one. I really enjoyed seeing the side passage that is being carved by erosion from the pre-flow soil. I had never before seen the lava cast of a tree from a worms eye view. Since there is no moss or lichen and the cast isn't exposed to the elements you can also see the imprint of bark and tree rings in the rock. The other plus is that when you get out of the side passage you actually look like you've been caving since the crawls were a little muddy. When we exited it was dark. Near the parking lot we ran into a group of guys heading for Lake with a beer in one hand and a couple of coolers between them. We had a trash bag full of garbage and it was disheartening to see them. We asked them to pack their trash out and they assured us they would.

The trip was capped off with a great Spaghetti dinner at Jim and Libby's with most of the people who were at the breakfast. Roger had a great story about caving with Gloria that I had heard him tell before, but that was before I knew Gloria. The highlights are a tight passage, an exploding pack, Gloria's soot covered face and temporary loss of hearing. You should have been there!

Attending:
Gloria Briggs, Mike Compton, Steve Sprague, Steve Weil, John Moore.

(Continued from page 7)

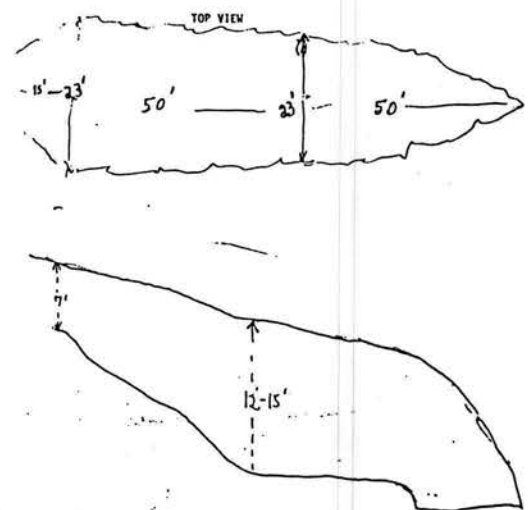
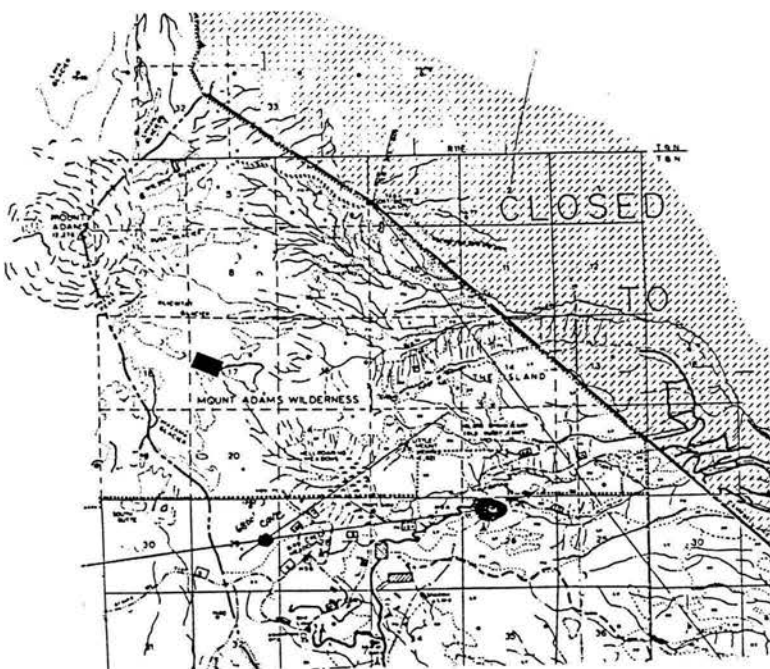

STEEL Tape survey by Charles and Howard Hoyt, August, 1992
Location by compass and triangulation by Charles Hoyt

The Grotto Library

By Mark Sherman

Not many of you realize that the Grotto has a book library, but we do. It hasn't been advertised much and when I was keeper of the books, I became tired of dragging them to the meetings and the not having anybody show interest in them so I started leaving them at home. If you ignore the hassle of hauling the books around and having to find a place to store them, the one nice thing about being the librarian was having the opportunity to read almost all of them. Here is a synopsis of the books that are in the library. ??????? is the new librarian, so if anyone is interested in any of these books, give ??????? a call. Hopefully, ??????? won't be the only one reading these.

Adventure is Underground: W. Halliday
1959, Harper & Brothers, Publishers

An account of the exploration of some of the major cave systems in the Western United States. This includes Carlsbad, Neff's Canyon, Cave of the Wind, and many of the California caves. It includes much about the folklore and history surrounding each of the caves.

Ape Cave and the Mt. St. Helens Apes:
W. Halliday 1983, ABC Printing and Publishing

The history and geology of Washington's longest and best known cave as well as one of the longest lava tubes in the United States.

Cave Craft-An Introduction to Caving and Potholing: D. Cons
1966, George C. Harrap & Co. LTD

A "how to" guide with a distinctive British flavor. It is somewhat outdated in the equipment section such as emphasizing the importance of nails on the bottoms of boots.

Cave Life:
C. Mohr 1956, Nelson Doubleday, Inc.

This book, put out by the Audubon society, starts out with a general description of different types of caves, their formations and how they are developed. It then goes into the different types of life you find in caves. The excellent photos are on stamps which have been passed in the book.

Caves of Adventure:
H. Tazieff 1953, The Viking Press

An excellent account of the 1951, 52 french expeditions to Pierre Saint-Martin in the Pyrenees. Most of the focus is geared to the tragic death of Marcel Loubens when he fell while ascending. Pierre Saint-Martin is one of the deepest caves in the

world with an entrance pit over 1000 feet deep. The cave also contains some of the largest chambers in the world

Caves of Washington: W. Halliday
1963, Washington Department of Conservation

A guidebook to the known caves in the state (as of 1963) along with descriptions and maps (when available).

Deep in Caves and Caverns:
L & G Poole 1962, Dodd, Mead & Company

This book seems to have been written for an audience of 7th graders. Trying to cover everything from the biology and geology of caves to prehistoric man in cave and modern exploration. In just 135 pages it does a poor job on everything.

Depths of the Earth:
W. Halliday 1966, Harper & Row, Publishers

A well written book dealing with caves and caving regions of the U.S. Each chapter talks about the exploration of a significant cave, such as Mammoth of Neff's Canyon Cave, or the people involved with a particular region.

Discovery of the Rion Camuy:
R & J Gurnee 1974, Crown Publishers, Inc.

The story of the exploration of the Rio Camuy Cave System in Puerto Rico. The author was tired of going caving in New York in the winter and decided to go someplace warm. This massive cave contains huge passages and chambers, tremendous waterfalls and many new species of marine and insect life. It also has many of the problems associated with following river passages such as flooding, which the cavers found out about the hard way.

Exploring American Caves:
F. Folsom 1962, Collier Books

Like most caving books, this one starts off with the origin of caves and their formations and then goes into the plant and animal life found in caves. This book then deals with man's use of caves from prehistoric times to today's commercial use. It covers the formation of the NSS and then talks about individual caves such as Schoolhouse and Carlsbad and finishes up with a talk about caving equipment.

Fifty Hikes in Mount Rainier National Park:
Spring & Manning 1969, The Mount Rainier Natural

History Association & the Mountaineers
A hiking guidebook to Mount Rainier National Park containing everything from afternoon nature walks to hiking the 100 mile Wonderland Trail.

Fire and Ice: S. Harris

1976, The Mountaineers, Pacific Search Press

This book covers the geology and history of the Cascade Volcanoes. Each chapter covers one of the major volcanoes.

Ghar Parau:

D. Judson 1973, Cassell & Company LTD

The story of the 1971 and 1972 British expeditions to one of the deepest caves in the world located in the Zagros Mountains on the Iran Iraq border. This story covers many of the problems this group went through in organizing and running an expedition to an obscure part of the world. This area might be a good candidate for a Grotto project.

Jim White's Story of Carlsbad Cavern:

J. White 1951

The history of Carlsbad from 1900 to the 1930's as told by the man who discovered and developed it. Interesting tales of his first trips into the cave and the problems he had with his torches and lanterns. At one point he is perched on a ledge and he is set on fire by his partner's torch. This copy appears to be signed by Jim White's wife.

MAWS:

Erd Noswat (R. Watson) 1976, Speleobooks

Cave humor in it's lowest form. Travel through Big Cave with Range K and the Speleologist as they locate the deep pit which is killing off all the Boysprouts and scaring the Sproutmothers away (this keeps them from sun bathing near the cave entrance which Ranger K has to supervise). Actually, it is a fun little book.

My Caves:

N. Casteret 1947, J.M. Dent & Sons LTD

The exploits of the French caver as he discusses "his caves" in the Pyrenees. It was published in 1947 so the discussions about equipment and technique are very interesting.

On Rope:

A. Padgett & B. Smith

1987, The National Speleological Society

This book was sponsored by the NSS vertical section and contains just about everything you would ever want to know about rope technique. It contains sections on ropes, harnesses, rigging, knots, ascending, descending and belaying.

Oregon Caves-Discovery and Exploration:

Walsh and Halliday 1971, Te-Cum-Tom Enterprises

The history of Oregon's best known cave along with the cave tour map.

Rediscovering the Bighorns:

Wyoming St. Historical Society 1976,

The Wyoming St. Historical Society

This is a pictorial comparison between the Bighorn Mountains in the 1900 and 1975. It also has maps showing the locations of each set of pictures and a brief description.

Ten Years Under the Earth:

N. Casteret 1938, The Greystone Press

Discoveries made by Norbert Casteret including primitive statues and paintings and finding the source of the Garonne River.

The Amateurs Guide to Caves and Caving:

D. McClurg 1973, Stackpole Books

Another "how to" guide for caving with discussion of types of equipment, safety and conservation.

The Darkness Under the Earth:

N. Casteret 1954, Henry Holt & Company

This book is divided into two parts, the first dealing with Ice Caves that he discovered in the 1920's with his wife and finally got to explore with his two daughters in the 50's. There are several black and white photos by Casteret. The second half deals with the dangers of caving. Each chapter talks about different type of hazard and then he discusses different examples of accidents due to these hazards. Not something you would want your wife, girlfriend, husband etc. to read before you go caving.

The First Book of Caves:

E. Hamilton 1956, Franklin Watts Inc.

This book, written for grade school kids gives a good overview of caves. It discusses how caves are formed and the types of formations, cavelife (both animal and plant), and how prehistoric man used caves. It then goes on to talk about how to go visit a cave, commercial and wild.

The Life of the Cave:

Mohr & Poulson 1966, McGraw Hill Book Company

As the name implies, this book covers the biology in caves. Some of the main topics include: how animals adapt to the darkness, the food chain, the different zones in the cave and what is found in each, and how man is having an impact on cave life. Excellent photos.

The Story of Caves:

D. Sterling 1956, Doubleday & Company, Inc.

Another good kids (approximately 10-14 years old) introduction to caving book. It covers all aspects of caves and caving from cave development and cave life to exploration and scientific study of caves. It also contains many illustrations.

Underground Worlds:

D. Jackson 1982, Time-Life Books

This Time-Life Book is really beautiful. I have had my own copy for about 4 years but had never gotten around to reading it until just recently. I would start looking at the drawings and pictures first and keep flipping through the pages. It has sections on how caves form, the history of speleology, equipment used in caving and cave life. It also has chapters on the explorations of well known caves like Carlsbad, Good Luck Cave in Sarawak, Mammoth and a section on Norbert Casteret explorations in the Pyrenees.

I would like to thank Mark Sherman for the time and effort he put into compiling the above book reports for us. I am sure he had many hours of enjoyable reading as I did when I was the Grotto Librarian. While we're on the subject of the Grotto library, I received the following request from our former brarian, Howard Hoyt:

"If you see a magazine article on caves or caving, please consider giving it to the Grotto Library. Wanted particularly: the March 1991, *National Geographic* magazine which contains the article on Lechuguilla Cave, New Mexico. Send donations to the Cascade Grotto Library. Any donations you make to the Grotto are tax deductible, as long as you receive a receipt for the items donated."

-Larry McTigue

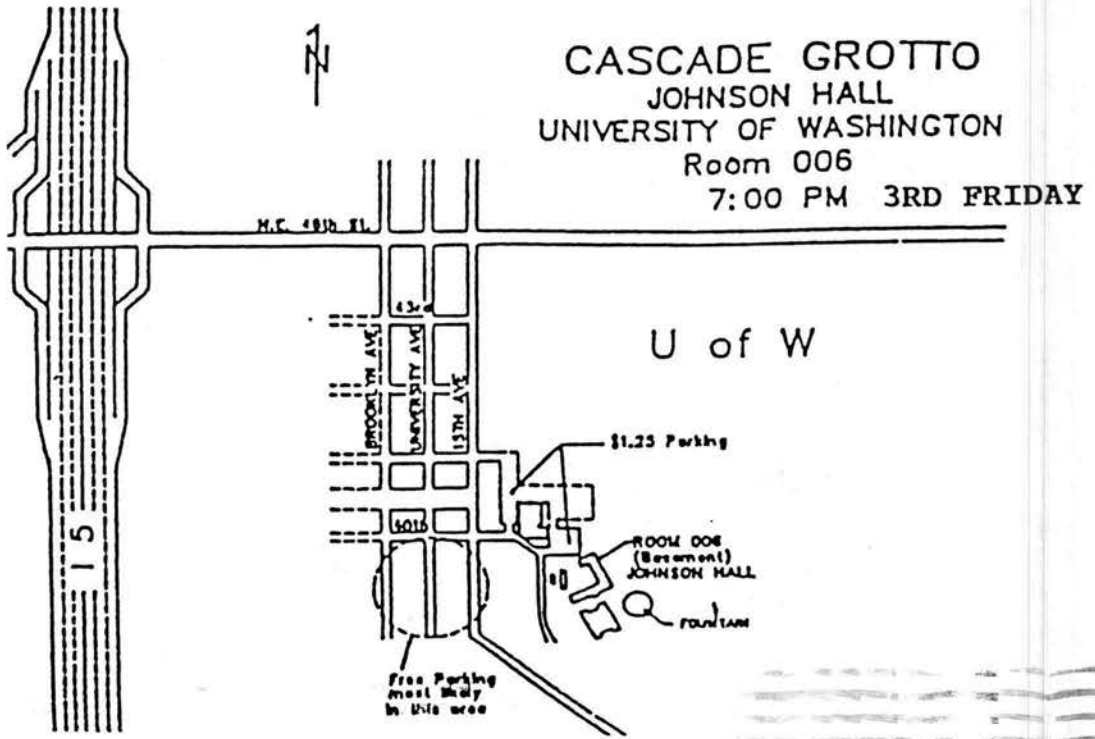

Cascade Cover
 P.O. Box 75663
 Seattle, WA 98125-0663



Paid to 99/99
 Windy City Grotto
 c/o Ralph Earlandson
 516 Harrison St #C
 Oak Park, IL 60304-1446

Address Correction Requested